

P ρ *T* Experimental Measurements and Data Correlation of Pentaerythritol Esters

Laura Fedele,* Sergio Marinetti, Sergio Bobbo, and Mauro Scattolini

National Research Council, Institute of Construction Technologies, Division of Padova, Corso Stati Uniti 4, 35127 Padova, Italy

The new refrigerant fluids are generally not compatible with traditional mineral oils used for the lubrication of compressors. Different typologies of oils have been proposed, such as polyalkylene glycol (PAG), alkylbenzene (AB), and polyol ester (POE) oils. New thermodynamic models are necessary to describe well the behavior of these fluids, but at the moment only few experimental data are available in the literature. The work presented in this paper is part of our research program aimed to evaluate the solubility of refrigerants in commercial oils. The density of five different pentaerythritol esters is presented, which are used as components of the commercial POE oils (i.e., pentaerythritol ester of butyric acid (PEC4), pentaerythritol ester of valeric acid (PEC5), pentaerythritol ester of hexanoic acid (PEC6), pentaerythritol ester of heptanoic acid (PEC7), and pentaerythritol ester of octanoic acid (PEC8)). The experimental compressed liquid density data were correlated by means of a particular equation that is also presented in this paper.

Introduction

Over the last several years, the substitution of the traditional refrigerants with alternative fluids has caused several important problems that are still not solved. One of them is the identification and development of new suitable lubricants. Although several groups of oils have been proposed, such as polyalkylene glycol (PAG), polyol ester (POE), or alkylbenzene (AB), their behavior in relation to the various refrigerants and applications is still not well-known. In particular, a lack of knowledge for the thermodynamic properties of the mixture refrigerant + lubricant, essential to properly design and operate the components of the refrigerating machines, is evident. Moreover, the data available in the literature often refer to commercial oils without a well-known structure, and they are not suitable to develop proper models able to predict the thermodynamic properties of the mixture refrigerant + lubricant. For these reasons, our research group is at present studying the solubility of carbon dioxide, one of the most interesting natural refrigerants, in pure pentaerythritol esters considered as precursors of POE oils (i.e., as components of the commonly used commercial oils). However, the measurement of the solubility and the development of thermodynamic models requires, as a preliminary step, the knowledge of the density of the oils. In this paper, compressed liquid density data are presented for five different precursors of POE oils (i.e., PEC4, PEC5, PEC6, PEC7, and PEC8).

For each oil, the density was measured along four isotherms at temperatures between (283.15 and 343.15) K, up to a maximum pressure of 35 MPa. The measurements were performed by means of an apparatus based on a vibrating tube densimeter (Anton Paar DMA 512), and the experimental data were compared with the available literature. The estimated temperature and pressure uncertainties are 0.02 K and 20 kPa, respectively. The maximum uncertainty in the measured densities ρ is estimated to be $0.6 \text{ kg}\cdot\text{m}^{-3}$. The experimental *P* ρ *T* data for the compressed liquid were also correlated with a proper equation.

Experimental Section

Materials. The five different pure pentaerythritol tetraalkyl esters mentioned above were used for the present measurements. The pentaerythritol esters oils are obtained by reacting pentaerythritol with carboxylic acids characterized by a different number of carbon atoms (from 3 carbons for butyric acid to 7 carbons for octanoic acid). The pentaerythritol ester molecules have four equal acid chains. Figure 1 shows the chemical structure of the pentaerythritol alkyl esters. The five pure esters were synthesized by Chemipan (Poland) on a laboratory scale with a declared purity higher than 98 %. To eliminate the non-condensable gases, each sample was put under vacuum and then used with no further purification. Table 1 shows some characteristics of the oils considered in this work.

Apparatus. The compressed liquid density data were measured using an apparatus with a stainless steel vibrating U-tube (Anton Paar DMA 512), already described in Bobbo et al.¹ A scheme of the apparatus is shown in Figure 2. This kind of measurements is based on the evaluation of the vibrating period (π) of a hollow resonating tube filled with the fluid under study, as a function of pressure *P* and temperature *T*. By means of a proper calibration function, this period can be converted into density.

The densimeter is connected to an electronic evaluation unit for the measurement of the oscillation period (Anton Paar mPDS 2000). Pressure is measured through a differential pressure gauge (Druck DPI 145) with a scale up to 35 MPa. The uncertainty in the pressure measurement is estimated to be within 20 kPa.

The temperature of the vibrating tube is stabilized by circulating water coming from an external thermostatic bath, through a heat exchanger surrounding the U-tube, reaching a stability of $\pm 0.003 \text{ K}$ all along the measurements. A thermal regulator allowed local fine temperature adjustment around the connection between the densimeter and the circuit by means of an electrical heating resistance controlled by a variable transformer. This ensures temperature and density uniformity inside the vibrating tube by reducing the heat flux through the connecting tubes. The temperature is measured by a PT 100 Ω resistance thermometer, and the estimated uncertainty in the

* Corresponding author. Tel: +39 049 8295831. Fax: +39 049 8295728. E-mail: laura.fedele@itc.cnr.it.

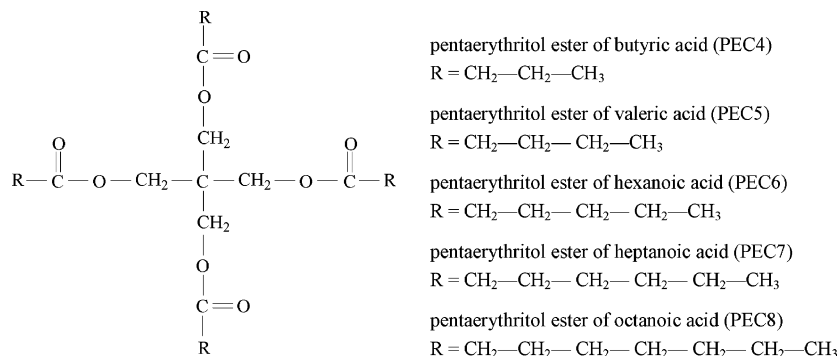

Figure 1. Chemical structure of the pentaerythritol tetraalkyl esters.

Table 1. Oils Used in the Measurements

chemical name (acronym)	chemical formula	molar mass
		$\text{kg}\cdot\text{kmol}^{-1}$
pentaerythritol ester of butyric acid (PEC4)	$\text{C}_{21}\text{H}_{36}\text{O}_8$	416.51
pentaerythritol ester of valeric acid (PEC5)	$\text{C}_{25}\text{H}_{44}\text{O}_8$	472.62
pentaerythritol ester of hexanoic acid (PEC6)	$\text{C}_{29}\text{H}_{52}\text{O}_8$	528.73
pentaerythritol ester of heptanoic acid (PEC7)	$\text{C}_{33}\text{H}_{60}\text{O}_8$	584.84
pentaerythritol ester of octanoic acid (PEC8)	$\text{C}_{37}\text{H}_{68}\text{O}_8$	640.94

temperature measurement is within 0.02 K.

Procedures. The circuit is first purged with acetone and blown out with nitrogen, afterward it is put under vacuum overnight with all the valves open except valves v_5 and v_6 . Then valves v_2 and v_3 are closed, and v_1 is opened in order to charge pure oil into the vibrating tube densimeter (VTD). In the meantime, valves v_5 and v_4 are opened, and the circuit between the nitrogen bottle (NB) and valve v_2 is charged with nitrogen gas through valve v_7 . Once, equilibrium is reached, valve v_1 and v_5 are closed, while valve v_2 is opened and the oil is pressurized with nitrogen to 35 MPa by means of the syringe pump (SP) (Isco Pump, model 260D). After the temperature stabilizes, the pressure inside the vibrating tube densimeter cell is gradually decreased at a rate of about $20 \text{ kPa}\cdot\text{s}^{-1}$ by the same syringe pump serving as a bleeding controller. The rate of pressure decrease diminishes during the measurements till around 5

$\text{kPa}\cdot\text{s}^{-1}$. Once the overtravel limits of the syringe pump is reached, the final pressure should be 1 atm. If the final pressure is higher than atmospheric pressure, it is possible to open the valve v_6 to achieve a further pressure decrease until the atmospheric pressure is reached. At this point, the liquid density isotherm is complete, and the fluid can be recompressed inside the circuit in order to measure a new isotherm after changing the measurement temperature.

Density Evaluation. A data acquisition system and proprietary software allow the continuous acquisition, visualization, and processing of the main experimental parameters (period, temperature, and pressure). An equation of state for the calibration fluid and the proper calibration function are also implemented into the software to compute in realtime the experimental density.

The densimeter is calibrated by measuring the oscillation period of the U-tube under vacuum and filled with a fluid of known density (i.e., water). For each constant temperature value, the calibration curve is

$$\pi^2 = (a \cdot p^2 + b \cdot p + c) \cdot \rho + B \quad (1)$$

where π is the oscillation period (in μs), p the pressure (in kPa), and ρ is the density (in $\text{kg}\cdot\text{m}^{-3}$). π is correlated to the known density of water at six different pressures regressing the coefficients a , b , and c , while B depends only on the oscillation

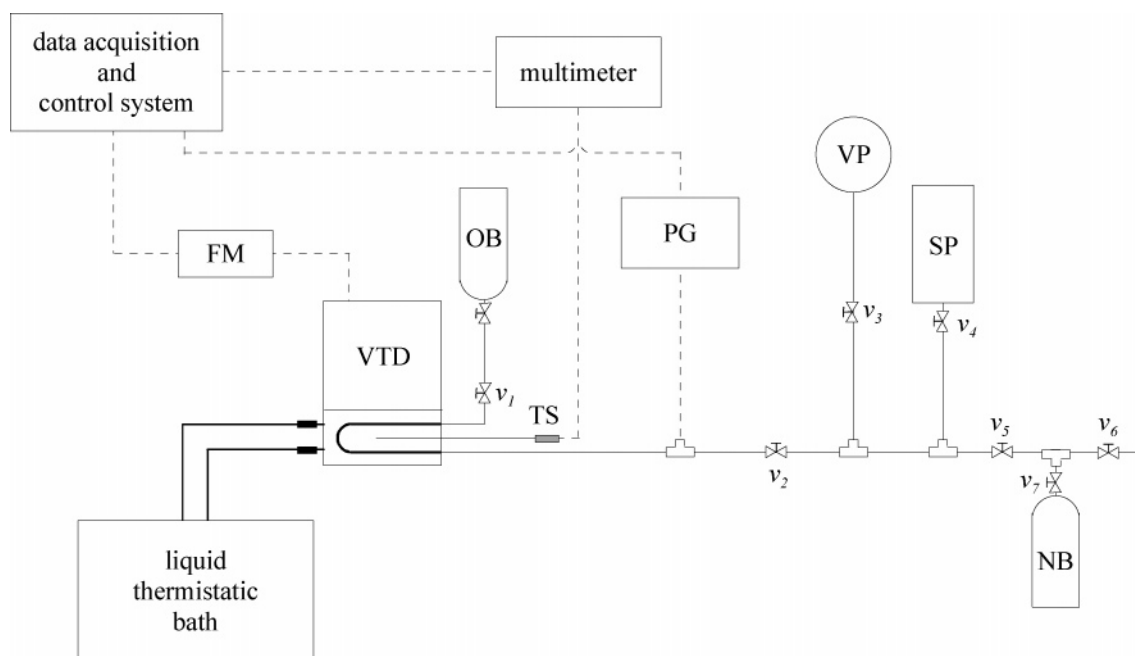

Figure 2. Density measurement apparatus scheme: SP, syringe pump; TS, temperature sensor; NB, nitrogen bottle; OB, pure oil bottle; PG, pressure gauge; FM, frequency meter; v_1, \dots, v_7 , valves; VP, vacuum pump; VTD, vibrating tube densimeter.

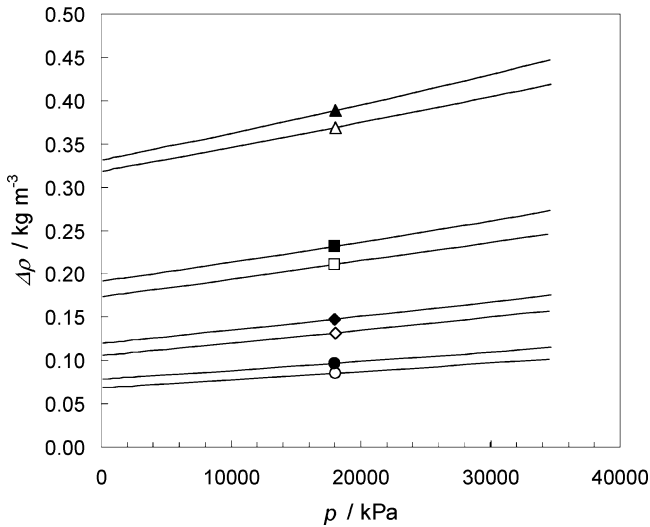

Figure 3. Correction factor due to viscosity for PEC5 (open symbols) and PEC7 (solid symbols) at Δ , 283.15 K; \square , 303.15 K; \diamond , 323.15 K; and \circ , 343.15 K. $\Delta\rho = \rho_{\text{exp}} - \rho_{\text{corr}}$.

Table 2. Total Uncertainty in the Density Measurements

Uncertainty of Pressure Measurements/kPa	
accuracy of pressure gauge	20
stability	3
total	23
Uncertainty of Temperature Measurements/K	
accuracy of thermometer	0.020
stability of thermostatic bath	0.003
total	0.023
Uncertainty of Period of Oscillation Measurements/ μs	
variation	0.020
counter accuracy	0.001
total	0.021
Uncertainty of Calibration (eq 1)/ $\text{kg}\cdot\text{m}^{-3}$	
uncertainty of equation of state	0.14
influence of period of oscillation fluctuations under vacuum	0.10
deviation from eq 1	0.10
total	0.34
Uncertainty in Density Calculation/ $\text{kg}\cdot\text{m}^{-3}$	
uncertainty in pressure measurements	0.002
uncertainty in temperature measurements	0.010
uncertainty in period of oscillation measurements	0.100
uncertainty of the calibration equation	0.340
total	0.452

period under vacuum. The equation proposed by Wagner and Pruss² is used to determine the water density at the calibration temperature and pressure.

As the present oils are quite viscous fluids, the measured density values should be corrected using the following equation recommended by Anton Paar³ for $\eta < 100 \text{ mPa}\cdot\text{s}$ for the employed densimeter (model DMA 512):

$$\frac{\rho_{\text{exp}} - \rho_{\text{corr}}}{\rho_{\text{exp}}} = (-0.5 + 0.45\sqrt{\eta}) \cdot 10^{-4} \quad (2)$$

where ρ_{exp} is the density value provided by the densimeter through eq 1, ρ_{corr} is the corrected value including the viscosity effect, and η is the dynamic viscosity (in $\text{mPa}\cdot\text{s}$).

For PEC5 and PEC7 the viscosity was calculated through the equations proposed by Pensado et al.^{4,5} and varied from (7 to 100) $\text{mPa}\cdot\text{s}$ and from (9 to 120) $\text{mPa}\cdot\text{s}$, respectively. Thus, the correction factor for these fluids is between (0.07 and 0.45) $\text{kg}\cdot\text{m}^{-3}$, being more significant at higher pressures and lower

Table 3. Selection of Experimental Compressed Liquid Density Values^a for PEC4, PEC6, and PEC8 Evenly Sampled from All of the Data Set

$T = 283.15 \text{ K}$		$T = 303.15 \text{ K}$		$T = 323.15 \text{ K}$		$T = 343.15 \text{ K}$	
p	ρ	p	ρ	p	ρ	p	ρ
kPa	$\text{kg}\cdot\text{m}^{-3}$	kPa	$\text{kg}\cdot\text{m}^{-3}$	kPa	$\text{kg}\cdot\text{m}^{-3}$	kPa	$\text{kg}\cdot\text{m}^{-3}$
PEC4							
34530	1078.2	34848	1063.1	34570	1047.8	34520	1032.8
30016	1075.8	30045	1060.6	30029	1045.1	30033	1030.0
26009	1073.6	26027	1058.1	26045	1042.6	26037	1027.1
22009	1071.6	22040	1055.9	22011	1040.0	22030	1024.5
18007	1069.4	18009	1053.6	18014	1037.5	18009	1021.6
14025	1067.1	14003	1051.1	14027	1034.8	14005	1018.7
10025	1064.8	10010	1048.7	12033	1033.4	10013	1016.0
6003	1062.6	6007	1046.3	8018	1030.7	6014	1012.8
2123	1060.1	2012	1043.6	6002	1029.3	2014	1009.7
104	1059.0	106	1042.2	3022	1026.7	104	1008.1
PEC6							
33005	1022.2	34434	1008.6	32404	993.5	34038	980.6
30016	1020.5	30006	1006.3	30027	992.1	30005	978.1
26003	1018.5	26004	1004	26003	989.7	26019	975.6
22008	1016.5	22018	1001.8	22005	987.2	22020	972.9
18002	1014.3	18010	999.4	18001	984.8	18017	970.3
14013	1012.1	14002	997.2	14020	982.3	14011	967.6
10013	1009.9	10030	994.7	10002	979.7	10011	964.7
6007	1007.7	6013	992.2	6015	976.8	6022	961.7
2005	1005.3	2014	989.6	2007	974.0	2012	958.6
91	1004.2	192	988.6	371	972.9	203	957.3
PEC8							
34410	988.5	34343	975.0	34474	962.0	33099	948.3
30032	986.4	30018	972.7	30013	959.4	30024	946.4
26005	984.3	26006	970.5	26028	957.1	26014	943.9
22008	982.4	22017	968.4	22025	954.7	22002	941.5
18037	980.2	18024	966.2	18019	952.4	18022	938.8
14031	978.1	14022	964.0	14007	949.9	14038	936.2
10030	975.8	10037	961.6	10026	947.2	10014	933.3
6009	973.7	6022	959.2	6024	944.7	6014	930.4
2021	971.4	2014	956.6	2017	941.9	2033	927.4
106	970.3	105	955.4	105	940.6	105	926.2

^a Density data not corrected considering viscosity with eq 2.

temperatures. The dependence of the viscosity correction with pressure and temperature is shown in Figure 3. The data are significantly affected by viscosity only at low temperature. Unfortunately, no viscosity data are available in the literature for PEC4, PEC6, and PEC8. For this reason, the data related to these oils are presented here without any correction.

The total uncertainty of the density measurement, estimated taking into account only the influence of temperature, pressure, period of oscillation, and water EoS uncertainties, is around $0.5 \text{ kg}\cdot\text{m}^{-3}$ as shown in Table 2. The major contribution comes from the calibration procedure. For viscous fluids, as explained before, the density data should be corrected with eq 2. The uncertainties in viscosity do not significantly influence the density evaluation through eq 2 and are thus neglected. However, eq 2 gives an uncertainty of about $0.1 \text{ kg}\cdot\text{m}^{-3}$ in the density calculation. Therefore, the total uncertainty of the corrected density values for viscous fluids is $0.6 \text{ kg}\cdot\text{m}^{-3}$. When this correction is not introduced (i.e., for PEC4, PEC6, and PEC8), the effect of viscosity should be added to the experimental uncertainty, considering the dependence with temperature and pressure as explained before, and the total density measurements uncertainty becomes roughly $1 \text{ kg}\cdot\text{m}^{-3}$.

The experimental density data obtained with the apparatus were previously validated by comparison with literature data.^{6,7} In Bobbo et al.,⁶ pentafluoroethane (R125) and 1,1-difluoroethane (R152a) density data were measured to prove the reliability of the apparatus, and the deviations between the experimental and the literature data were within $\pm 0.1 \%$.

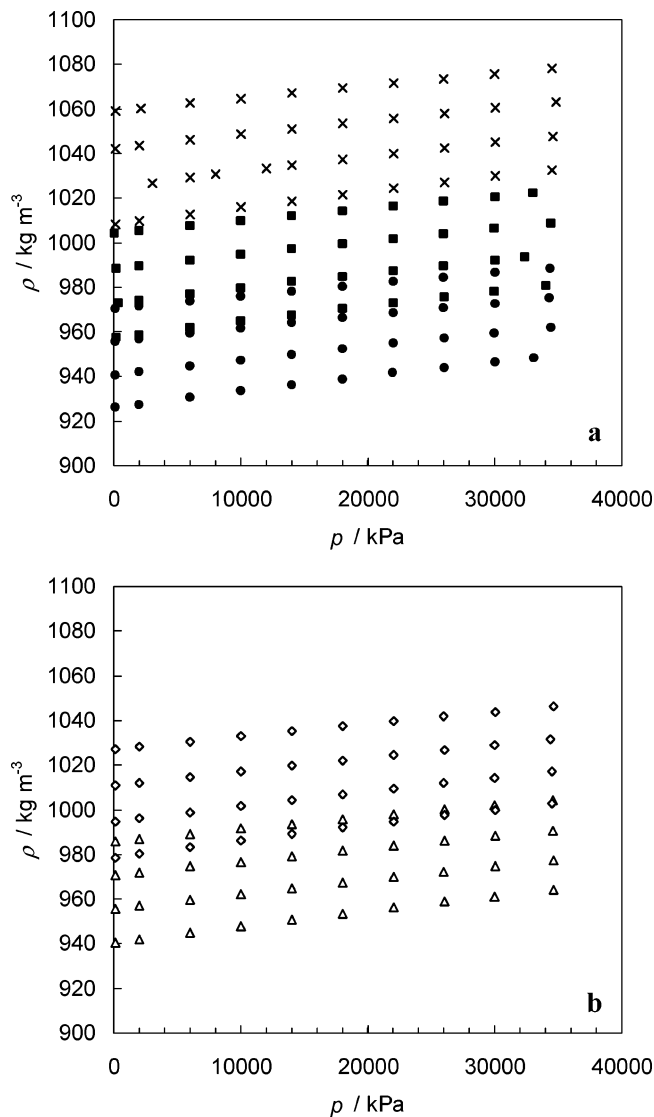

Figure 4. Distribution of the selected experimental compressed liquid density data for the different PEC oils. (a) ×, PEC4; ■, PEC6; ●, PEC8 (density data not corrected considering viscosity with eq 2). (b) ◇, PEC5; △, PEC7 (density data corrected considering viscosity with eq 2).

Moreover, Span and Lemmon⁷ propose an equation of state able to represent the density data of 1,1,1,3,3-pentafluoropropane (R245fa) measured with this apparatus⁶ within 0.1 %, well centered on zero.

Results and Discussion

Compressed Liquid Density. The main aim of this study is to provide new data for the compressed liquid density of PEC4, PEC5, PEC6, PEC7, and PEC8. A total of 32441 compressed liquid density values were measured at isothermal conditions in the temperature range from (283 to 343) K and pressures up to 35 MPa. A selection of these data is summarized in Table 3 and in Figure 4a for PEC4, PEC6, and PEC8 and in Table 4 and Figure 4b for PEC5 and PEC7. All the measured data are available in the Supporting Information via the Internet (see Supporting Information section).

All of the experimental data in the temperature range between (283.15 and 343.15) K were correlated by means of a proper equation, derived by the generalized Tait equation in the form⁸

$$v = v_{\text{sat}} \left(1 - c \ln \frac{\beta + p}{\beta + p_{\text{sat}}} \right) \quad (3)$$

Table 4. Selection of Experimental Compressed Liquid Density Values^a for PEC5 and PEC7 Evenly Sampled from All of the Data Set

$T = 283.15\text{K}$		$T = 303.15\text{K}$		$T = 323.15\text{K}$		$T = 343.15\text{K}$	
p	ρ	p	ρ	p	ρ	p	ρ
kPa	$\text{kg}\cdot\text{m}^{-3}$	kPa	$\text{kg}\cdot\text{m}^{-3}$	kPa	$\text{kg}\cdot\text{m}^{-3}$	kPa	$\text{kg}\cdot\text{m}^{-3}$
PEC5							
34639	1046.1	34388	1031.3	34510	1017.0	34514	1002.8
30019	1043.7	30016	1028.9	30012	1014.3	30022	999.9
26009	1041.6	26023	1026.6	26007	1011.9	26041	997.5
22024	1039.5	22009	1024.5	22029	1009.4	22008	994.7
18026	1037.4	18012	1022.1	18025	1006.8	18030	992.0
14021	1035.1	14011	1019.6	14014	1004.2	14014	989.2
10006	1032.8	10009	1017.3	10018	1001.6	10011	986.2
6018	1030.5	6015	1014.7	6002	998.9	6021	983.2
2007	1028.2	2006	1012.1	2015	996.1	2019	980.2
106	1027.1	107	1010.8	106	994.6	106	978.6
PEC7							
34576	1004.3	34556	990.7	34625	977.3	34659	964.1
30003	1002.0	30029	988.3	30032	974.6	30006	961.3
26012	1000.1	26038	986.0	26002	972.3	26012	958.8
22022	997.9	22017	983.9	22010	969.9	22010	956.2
18017	995.9	18010	981.6	18001	967.4	18012	953.5
14003	993.7	14023	979.3	14002	964.9	14004	950.8
10018	991.6	10026	976.8	10011	962.4	10018	947.9
6000	989.2	6016	974.6	6016	959.6	6002	945.0
2001	987.0	2007	971.9	2004	957.1	2001	942.1
100	986.0	100	970.9	100	955.7	100	940.6

^a Density data corrected considering viscosity with eq 2.

where v is the molar volume (in $\text{L}\cdot\text{mol}^{-1}$), v_{sat} is the saturated molar volume, p is the pressure (in kPa), and p_{sat} is the saturated pressure. Moreover

$$\beta = p_c [-1 + a(1 - T_r)^{1/3} + b(1 - T_r)^{2/3} + d(1 - T_r) + e(1 - T_r)^{4/3}] \quad (4)$$

$$e = \exp(f + g\omega + h\omega^2) \quad (5)$$

$$c = j + k\omega \quad (6)$$

where $T_r = T/T_c$ is the reduced temperature and ω is the acentric factor calculated through the basic equation. The subscript c indicates the critical properties.

The problem for these oils is that v_{sat} , p_{sat} , p_c , and T_c data are not always available in the literature. For this reason, eq 3 was rewritten as follows:

$$v = \delta - \gamma \ln(\beta + p) \quad (7)$$

with

$$\delta = v_{\text{sat}}(1 + c \ln(\beta + p_{\text{sat}})) \quad (8)$$

$$\gamma = v_{\text{sat}} \cdot c \quad (9)$$

β , δ , and γ are dependent on temperature and regressed using the following polynomials:

$$\beta(T) = a_\beta \cdot T^2 + b_\beta \cdot T + c_\beta \quad (10)$$

$$\delta(T) = a_\delta \cdot T^2 + b_\delta \cdot T + c_\delta \quad (11)$$

$$\gamma(T) = a_\gamma \cdot T^2 + b_\gamma \cdot T + c_\gamma \quad (12)$$

Then for each isotherm the density can be represented by

Table 5. Coefficients of Equations 10 to 12 and Deviation between the Experimental and the Calculated Data^a

	<i>a</i>	<i>b</i>	<i>c</i>	AAD($\Delta\rho$)	AAD($\Delta\rho$ %)	$\Delta\rho_{max}$ %	T_{max}/K	p_{max}/kPa
				PEC4 ^b				
δ	0.00981118	-6.07440	1711.7120	0.09	0.01	0.04	323.15	3046
γ	0.00074232	-0.46866	105.6098					
β	5.69540009	-4364.65706	922992.8680					
				PEC5 ^c				
δ	-0.00256779	1.82012	607.2150	0.06	0.01	0.03	303.15	10382
γ	-0.00021466	0.14072	15.8326					
β	1.50932890	-1689.71411	500021.2546					
				PEC6 ^b				
δ	0.00455274	-2.46903	1388.6569	0.05	0.01	-0.03	323.15	591
γ	0.00034205	-0.19592	72.5464					
β	3.12255381	-2656.50400	644281.5837					
				PEC7 ^c				
δ	-0.03794223	25.07360	-2944.2885	0.07	0.01	0.03	343.15	14855
γ	-0.00295511	1.93953	-267.9211					
β	-7.17024375	4030.46840	-441869.0142					
				PEC8 ^b				
δ	-0.06359457	40.99671	-5247.1246	0.08	0.01	0.06	303.15	29263
γ	-0.00496160	3.18345	-452.4288					
β	-10.75188071	6221.87664	-771428.2291					

^a N_p = number of points. $AAD(\Delta\rho) = (\sum_{i=1}^{N_p} |\rho_{calc} - \rho_{exp}|)/N_p$. $AAD(\Delta\rho \%) = 100 \cdot \{\sum_{i=1}^{N_p} |[(\rho_{calc} - \rho_{exp})/\rho_{exp}]|\}/N_p$. ^b Parameters regressed on density data not corrected with eq 2. ^c Parameters regressed on density data corrected with eq 2.

Table 6. Saturated Liquid Density Data for RE170

data from eq 14		data from ref 7		
<i>T</i>	ρ_{sat}	<i>T</i>	p_{sat}	ρ_{sat}
K	kg·m ⁻³	K	kPa	kg·m ⁻³
283.15	683.7	283.15	371	684.5
293.15	668.3	293.15	506	669.1
303.15	651.9	303.15	676	653.4
313.15	634.1	313.15	885	636.6
323.15	614.9	323.15	1139	618.9
333.15	593.8	333.15	1444	600.0
343.15	570.4	343.15	1806	580.7

Table 7. Saturated Liquid Density Data of PEC4, PEC5, PEC6, PEC7, and PEC8

oil	<i>T/K</i>	$\rho_{sat}/kg\cdot m^{-3}$
PEC4 ^a	283.15	1059.0
	303.15	1042.1
	323.15	1025.0
	343.15	1007.9
PEC5 ^b	283.15	1027.0
	303.15	1010.8
	323.15	994.5
	343.15	978.5
PEC6 ^a	283.15	1004.1
	303.15	988.3
	323.15	972.6
	343.15	957.1
PEC7 ^b	283.15	985.9
	303.15	970.6
	323.15	955.6
	343.15	940.5
PEC8 ^a	283.15	971.0
	303.15	955.9
	323.15	941.4
	343.15	926.6

^a Saturated liquid density data calculated through eq 14 with the parameters regressed on density data not corrected with eq 2. ^b Saturated liquid density data calculated through eq 14 with the parameters regressed on density data corrected with eq 2.

$$\rho = \frac{1000 \cdot \overline{MM}}{\delta(T) - \gamma(T) \ln(\beta(T) + p)} \quad (13)$$

where ρ is the density (in kg·m⁻³) and \overline{MM} is the molecular mass. The β , δ , and γ parameters are summarized in Table 5.

The deviations between eq 13 and the selected experimental data are shown in Figure 5, as a function of temperature and pressure, and summarized in Table 5, where the maximum deviations for the whole isotherms are also indicated.

In order to evaluate the ability of eq 13 to represent the compressed liquid density, data for dimethyl ether (RE170), already published,⁹ were treated with this model. The absolute average deviation (AAD) between the calculated and the experimental data was about 0.03 %, comparable with that obtained with the original Tait equation in ref 9.

Saturated Liquid Density. Saturated density data for these oils and especially saturated pressure data were not found in the literature. For this reason, extrapolation to saturated conditions was not possible.

However, starting from eq 7, the authors propose a method to estimate this property. In fact, considering the low saturated pressure of the oils, eq 7 can be written as

$$v_{sat} = \delta - \gamma \ln(\beta) \text{ with } \beta \gg p_{sat} \quad (14)$$

This approximation involves a percentage error in terms of density given by

$$\Delta\rho_{sat} \% = 100 \frac{\frac{(1000 \cdot \overline{MM})}{\delta - \gamma \ln(\beta)} - \frac{(1000 \cdot \overline{MM})}{\delta - \gamma \ln(\beta + p_{sat})}}{\frac{(1000 \cdot \overline{MM})}{\delta - \gamma \ln(\beta + p_{sat})}} = 100 \cdot \frac{\gamma \ln\left(\frac{\beta}{\beta + p_{sat}}\right)}{\delta - \gamma \ln(\beta)} \quad (15)$$

This error is shown in Figure 6 for all the present oils and RE170 at 283.15 K, where the behavior for different temperatures is very similar. It is evident that the higher the ratio β/p_{sat} , the smaller the error in the prediction of the saturated density. Considering that for the measured oils the saturated pressure is very low, certainly lower than atmospheric pressure and the β coefficients are always higher than 10⁵, this prediction can be very reasonable, and the systematic error introduced by eq 15 is negligible.

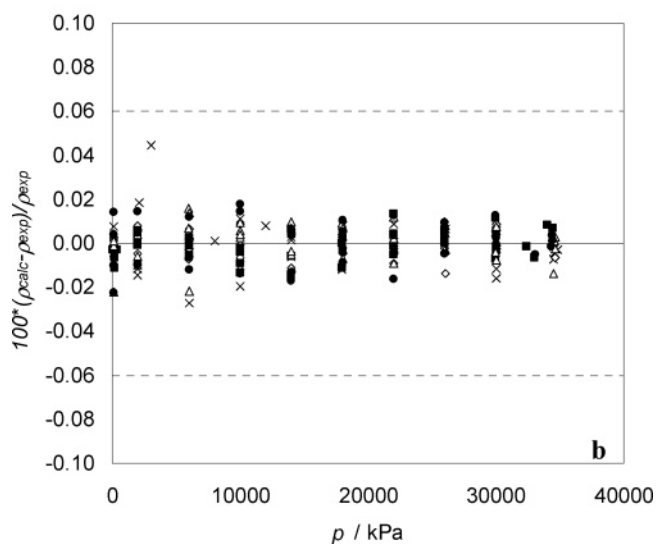
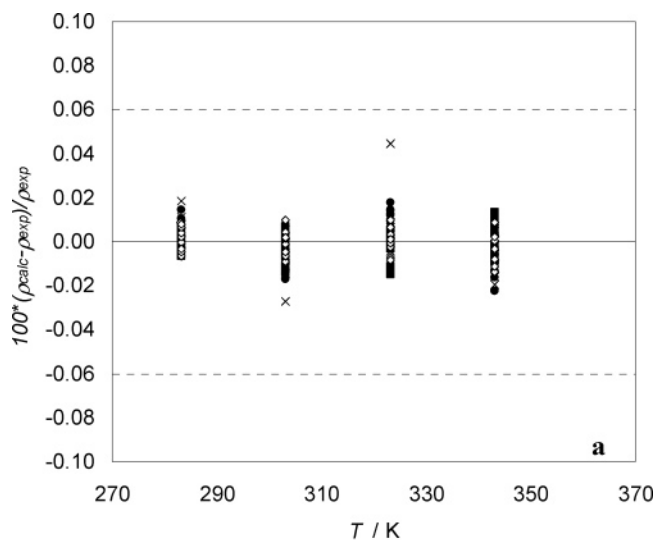

Figure 5. Deviations between the experimental selected and the calculated liquid compressed density data for the oils from eq 13 as a function of temperature (a) and pressure (b). \times , PEC4 (density data not corrected considering viscosity with eq 2); \diamond , PEC5 (density data corrected considering viscosity with eq 2); \blacksquare , PEC6 (density data not corrected considering viscosity with eq 2); \triangle , PEC7 (density data not corrected considering viscosity with eq 2); \bullet , PEC8 (density data not corrected considering viscosity with eq 2).

Equation 14 was applied to the already published data of RE170 in order to evaluate the equation. This choice is due to the fact that the saturated volume of this fluid is known, although the ratio β/p_{sat} is much lower than that expected for PECs. The saturated density calculated by means of eq 14 and the literature data are summarized in Table 6.

The deviations vary from 0.1 % at 283.15 K to 1.8 % at 343.15 K, as the β/p_{sat} ratio decreases from 98 to 5 and are reported in Figure 7, where the predicted error of eq 14 is shown as well. The saturated density data for the PECs are summarized in Table 7 as a function of temperature and are shown in Figure 8.

Comparison with the Literature Data. Few data on the liquid density of the pentaerythritol ester oils have been published in the literature. Shobha and Kishore¹⁰ and Wahlstrom and Vamling¹¹ published some density data at several temperatures and atmospheric pressure. Moreover, some compressed liquid density data were published in the literature for PEC5 by Fandiño et al.¹² and for PEC7 by Fandiño et al.¹³ Experiments

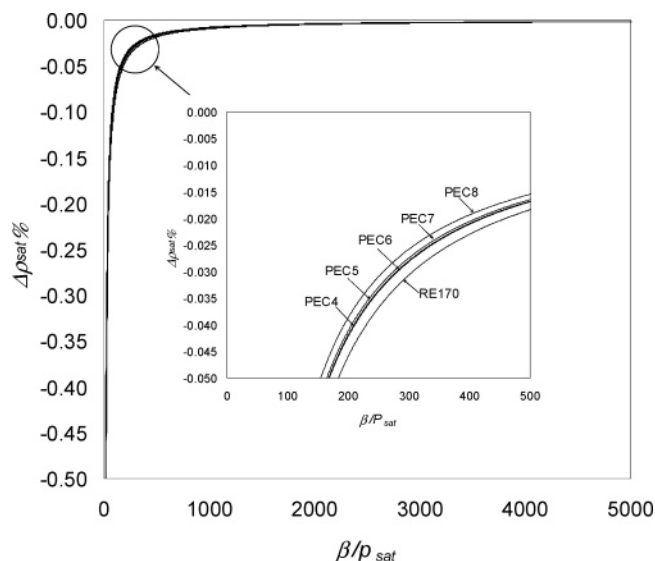

Figure 6. Error made in the prediction of the saturated density data by means of eq 14. $\Delta\rho_{\text{sat}}\%$ as defined by eq 15.

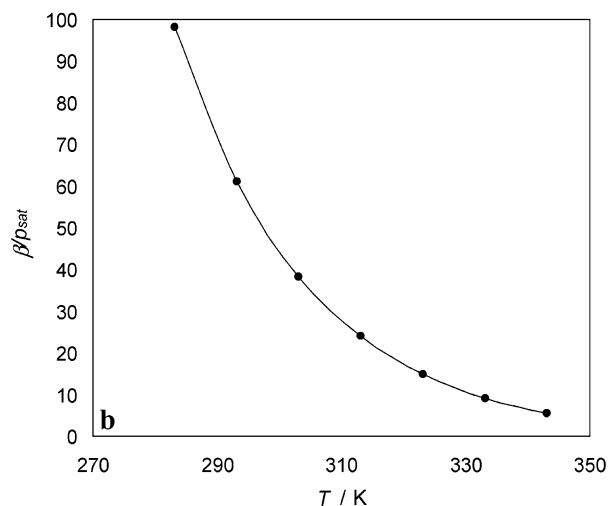
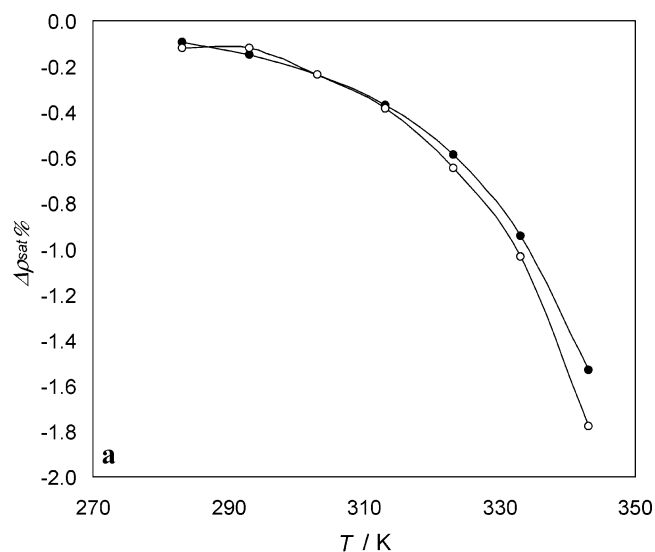

Figure 7. (a) Deviation between \circ , the estimated density data calculated with eq 14 and the literature data;⁷ \bullet , the estimated error of eq 14 with eq 15 for RE170. (b) β/p_{sat} as a function of temperature for RE170.

were carried out in the temperature range from (278.15 to 353.15) K, while the pressure varied between (0.1 and 45) MPa.

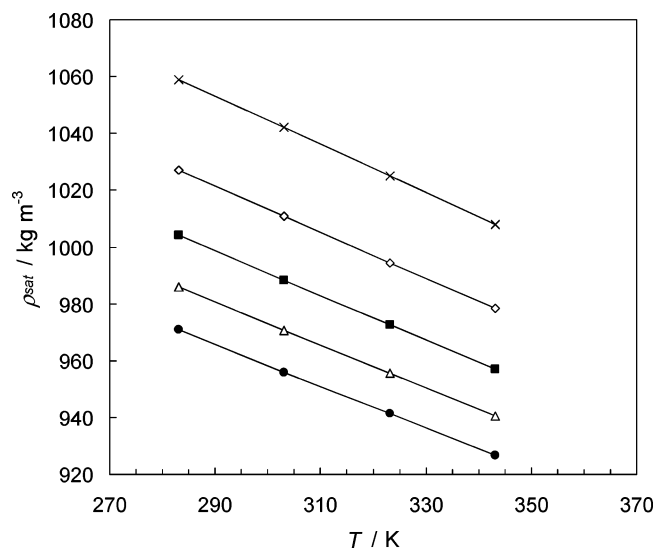

Figure 8. Saturated density data evaluated with eq 14: \times , PEC4¹¹ \diamond , PEC5 (saturated liquid density data calculated through eq 14 with the parameters regressed on density data corrected with eq 2); \blacksquare , PEC6 (saturated liquid density data calculated through eq 14 with the parameters regressed on density data not corrected with eq 2); \triangle , PEC7 (saturated liquid density data calculated through eq 14 with the parameters regressed on density data corrected with eq 2); \bullet , PEC8 (saturated liquid density data calculated through eq 14 with the parameters regressed on density data not corrected with eq 2).

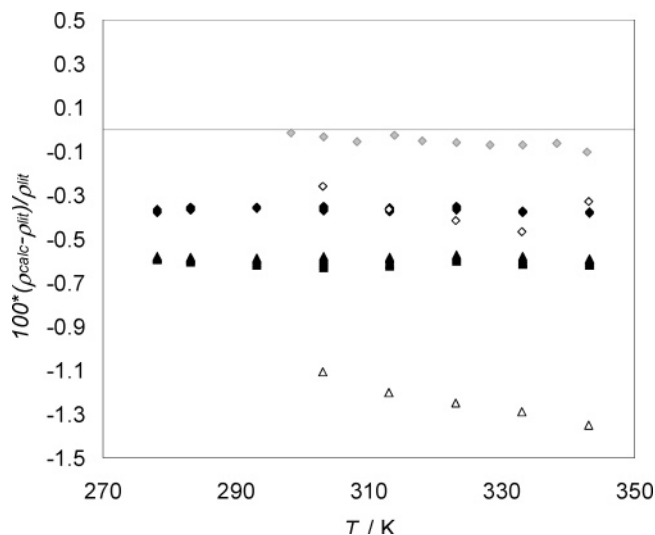

Figure 9. Relative deviation between the literature data^{8–11} (ρ_{lit}) and eq 13 (ρ_{calc}): \diamond ,⁸ gray diamond,⁹ \blacklozenge ,¹⁰ PEC5; \triangle ,⁸ \blacktriangle ,¹¹ PEC7.

Shobha and Kishore measured the density data by means of a mercury-calibrated dilatometer, declaring an uncertainty in the measurements of about 0.2 %. Furthermore, they proposed a fitting equation able to represent the data within 1.5 %. Wahlstrom and Vamling used an Anton Paar DMA 602 vibrating tube densimeter, reporting an uncertainty in the density measurements of about 0.1 %. Fandiño et al. declared an uncertainty of 0.1 kg·m⁻³, being the density data measured by means of an Anton Paar DMA 512P vibrating tube. Regarding the PEC5 density measurements, Fandiño et al. published both the uncorrected and the corrected values due to viscosity, but the latter were considered here only for the comparison. The deviations between the literature data and eq 13 are shown in Figure 9.

Our data of PEC5 and PEC7 exhibit deviations from those of Shobha and Kishore varying between (−0.2 and −1.4) %.

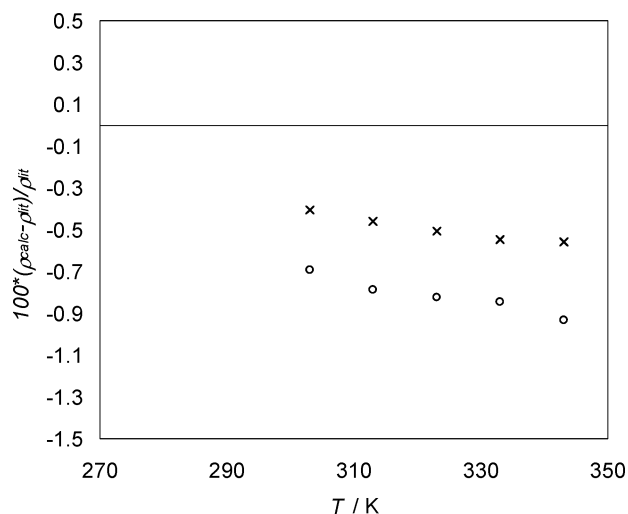

Figure 10. Relative deviation between the literature data⁸ (ρ_{lit}) and eq 13 (ρ_{calc}): \times , PEC4; \circ , PEC8.

However, considering the literature data trend, it seems that these data are scattered, probably due to the employed experimental procedure.

The data of Wahlstrom and Vamling seem to be more consistent, with deviations from eq 13 between (−0.02 and −0.10) %. However, a slight trend of the deviations with the temperature is evident.

The data of Fandiño et al. show a systematic offset of about −0.4 % for PEC5 and about −0.6 % for PEC7. Since Fandiño et al. declared a purity of the synthesized oils higher than 95 %, this deviation could be explained by the samples purity differences.

Figure 10 summarizes the deviations between the literature data for PEC4 and PEC8 measured by Shobha and Kishore and eq 13. These data exhibit deviations from (−0.4 to −0.9) %.

Conclusions

In this paper experimental compressed liquid density data for five polyol ester oils (i.e., pentaerythritol ester of butyric acid (PEC4), pentaerythritol ester of valeric acid (PEC5), pentaerythritol ester of hexanoic acid (PEC6), pentaerythritol ester of heptanoic acid (PEC7), and pentaerythritol ester of octanoic acid (PEC8)) are presented in the temperature range between (283.15 and 343.15) K. A fitting equation is proposed able to represent these data within ± 0.03 %. Saturated liquid density data were calculated by means of this equation.

Supporting Information Available:

All of the experimental data. This material is available free of charge via the Internet at <http://pubs.acs.org>.

Literature Cited

- (1) Bobbo, S.; Fedele, L.; Scattolini, M.; Camporese, R. Compressed liquid densities, saturated liquid densities, and vapor pressures of hexafluoro-1,3-butadiene (C₄F₆). *J. Chem. Eng. Data* **2002**, *47*, 179–182.
- (2) Wagner, W.; Pruss, A. The IAPWS formulation 1995 for the thermodynamic properties of ordinary water substance for general and scientific use. *J. Phys. Chem. Ref. Data* **2002**, *31*, 387–535.
- (3) Anton Paar GmbH, private communication.
- (4) Pensado, A. S.; Comuñas, M. J. P.; Lugo, L.; Fernandez, J. High-pressure characterization of dynamic viscosity and derived properties for squalane and two pentaerythritol ester lubricants: pentaerythritol tetra-2-ethylhexanoate and pentaerythritol tetrananoate. *Ind. Eng. Chem. Res.* **2006**, *45*, 2394–2404.
- (5) Pensado, A. S.; Comuñas, M. J. P.; Fernandez, J. Relations between viscosity coefficients and volumetric properties. Measurements and modeling for pentaerythritol esters. Submitted to *Ind. Eng. Chem. Res.*

- (6) Bobbo, S.; Scattolini, M.; Fedele, L.; Camporese, R. Compressed liquid densities and saturated liquid densities of HFC-245fa. *Proceedings of the XXI IIR International Congress of Refrigeration*, Washington, DC, August 17–22, 2003.
- (7) Span, R.; Lemmon, E. W. Short fundamental equations of state for 20 industrial fluids. *J. Chem. Eng. Data* **2006**, *51*, 785–850.
- (8) Thomson, G. H.; Brobst, K. R.; Hankinson, R. W. An improved correlation for densities of compressed liquids and liquid mixtures. *AIChE J.* **1982**, *28*, 671–676.
- (9) Bobbo, S.; Scattolini, M.; Fedele, L.; Camporese, R.; De Stefani, V. Compressed liquid densities and saturated liquid densities of dimethyl ether (RE170). *J. Chem. Eng. Data* **2005**, *50*, 1667–1671.
- (10) Shobha, H. K.; Kishore, K. Structural dependence of density in high molecular weight esters. *J. Chem. Eng. Data* **1992**, *37*, 371–376.
- (11) Wahlstrom, A.; Vamling, L. Solubility of HFC32, HFC125, HFC134a, HFC143a, and HFC152a in a pentaerythritol tetrapentanoate ester. *J. Chem. Eng. Data* **1999**, *44*, 823–828.
- (12) Fandiño, O.; Garcia, J.; Comuñas, M. J. P.; Lopez, E. R.; Fernandez, J. *PpT* measurements and equation of state (EoS) predictions of ester lubricants up to 45 MPa. *Ind. Eng. Chem. Res.* **2006**, *45*, 1172–1182.
- (13) Fandiño, O.; Pensado, A. S.; Lugo, L.; Lopez, E. R.; Fernandez, J. Volumetric behaviour of the environmentally compatible lubricants pentaerythritol tetraheptanoate and pentaerythritol tetranonanoate at high pressures. *Green Chem.* **2005**, *7*, 775–783.

Received for review June 16, 2006. Accepted October 30, 2006.

JE060271A